

Motor-Einstellwerkzeug-Satz

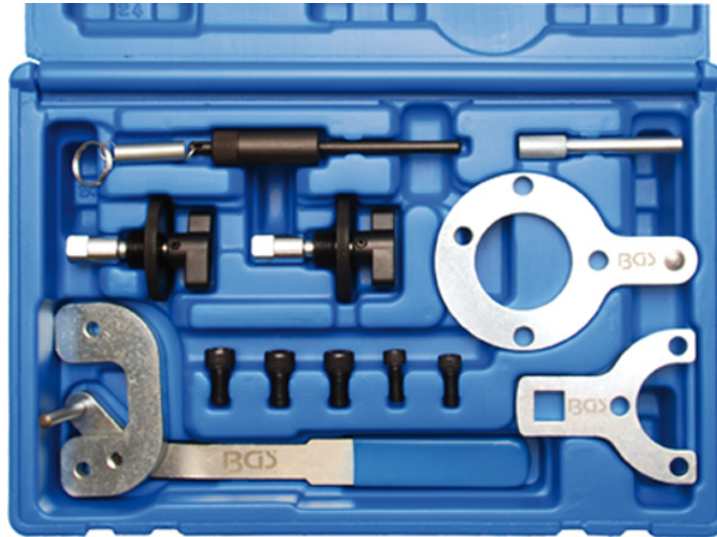

ALLGEMEIN

Dieser Motor-Einstellsatz ermöglicht eine Kontrolle und ein Einstellen der Motorsteuerzeiten und ist passend für die Modelle:

- Fiat:** Punto 1.3 JTD Multi-Jet 188A9.000 2003 - 2007
Panda 1.3 JTD Multi-Jet 169A1.000 & 188A8.000 2003 - 2009
Idea 1.3 JTD Multi-Jet 199A3.000 & 188A9.000 2004 - 2006
Doblo 1.3 JTD Multi-Jet 188A9.000 2004 - 2006
Doblo Cargo 1.3 JTD 188A9.000 2004 – 2006
- Opel (Vauxhall):** Agila 1.3 CDTi Z13DT 2003 - 2008
Corsa-C 1.3 CDTi Z13DT 2003 - 2007
Combo-C 1.3 CDTi Z13DT 2003 - 2009
Corsa-D 1.3 CDTi Z13DTH & Z13DTJ 2006 - 2009
Astra-H 1.3 CDTi Z13DTH 2004 - 2009
Tigre-B 1.3 CDTi Z13DT 2004 - 2009
Meriva 1.3 CDTi Z13DT & Z13DTJ 2004 – 2009
- Suzuki:** Ingis 1.3 CDTi Z13DT 2003 - 2009
Wagon 1.3 CDTi Z13DT 2003 - 2009
Swift 1.3 CDTi Z13DT 2003 – 2010
- Ford:** KA 1.3 TDCi

SICHERHEITSHINWEISE

- Verwenden Sie das Werkzeug nicht, wenn Teile fehlen oder beschädigt sind.
- Legen Sie das Werkzeug niemals auf die Fahrzeug-Batterie. Gefahr von Kurzschluss.
- Vorsicht bei Arbeiten an laufenden Motoren. Lose Kleidung, Werkzeuge und andere Gegenstände können von drehenden Teilen erfasst werden und zu schweren Verletzungen führen.
- Halten Sie Kinder und andere unbefugte Personen vom Arbeitsbereich fern.
- Vorsicht bei Arbeiten an heißen Motoren, es besteht Verbrennungsgefahr!
- Entfernen Sie vor der Reparatur den Zündschlüssel, so verhindern Sie ein versehentliches Starten des Motors und einen dadurch entstehenden Motorschaden.
- Diese Anleitung dient als Kurzinformation und ersetzt keinesfalls ein Werkstatthandbuch.
- Verwenden Sie immer eine fahrzeugspezifische Serviceliteratur. Aus dieser entnehmen Sie bitte technische Angaben wie Drehmomentwerte, Hinweise zur Demontage/Montage, usw.
- Nach erfolgter Reparatur bzw. vor dem Starten den Motor min. 2 Umdrehungen von Hand drehen und die Steuerzeiten erneut überprüfen.
- Verwenden Sie keine Reinigungsmittel zum Reinigen von Zahnriemen, Zahnrädern oder Rollen
- Drehen Sie den Motor nur in normaler Drehrichtung (im Uhrzeigersinn soweit nicht anders angegeben)

WERKZEUGE

A
Gegenhalteschlüssel für
Kurbelwellen-Riemenscheibe

zu verwenden wie OEM
Fiat OEM 1 871 000 200
Ford OEM 303-1469

Opel
Vauxhall OEM KM-662-C

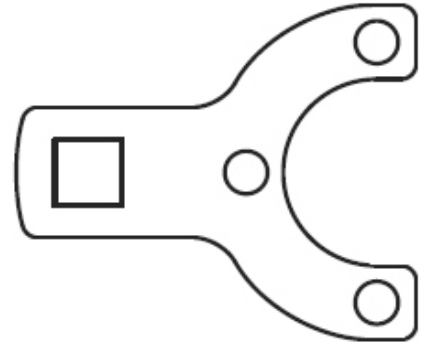

B
Kurbelwellen-Einstellwerkzeug

zu verwenden wie OEM
Opel (Vauxhall) EN 46785
Opel (Vauxhall) KM 955
Suzuki 09912-38300

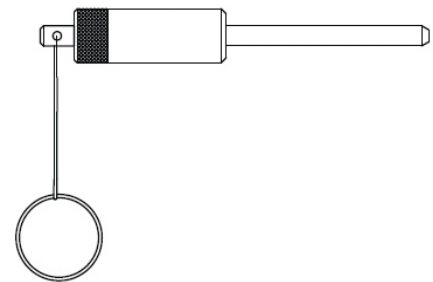

C
Nockenwellen-Einstellwerkzeug

zu verwenden wie OEM
Fiat 1 871 000 900
Fiat 1 860 985 000
Ford 303-1472
Opel (Vauxhall) EN 46781
Suzuki 09917-68610

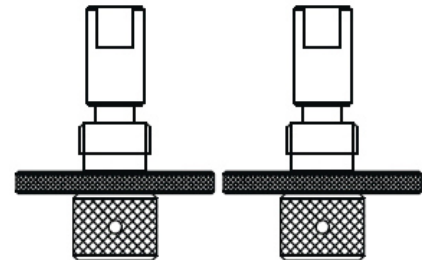

D
Ketten-Spannhebel

zu verwenden wie OEM
Fiat 1 870 900 400

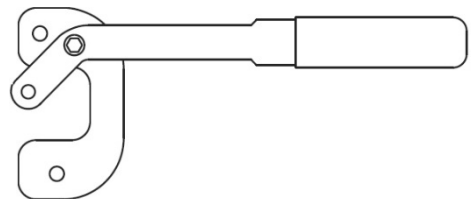

E
Kurbelwellen-Arretierwerkzeug

zu verwenden wie OEM
Fiat 1 870 900 300
Ford 303-1468

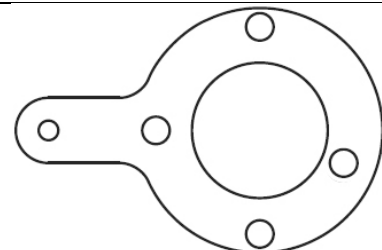

F
Kurbelwellen- Einstellwerkzeug

Fiat 8 mm

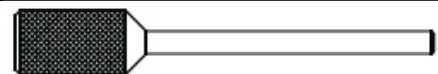

ANWENDUNG

A

Wird verwendet als Gegenhalteschlüssel beim Lösen der Zentralverschraubung (Linksgewinde) vom Flansch der Kurbelwellen-Riemenscheibe. Zur Montage des Werkzeugs müssen die 4 Schrauben der Riemenscheibe und die Riemenscheibe selber demontiert werden.

Hinweis: Die Zentralschraube nicht lösen, während der Absteckdorne für Nocken- oder Kurbelwelle angebracht ist, da sonst die Werkzeuge beschädigt werden. Beim Lösen und Festziehen der Zentralschraube immer den Gegenhalteschlüssel verwenden.

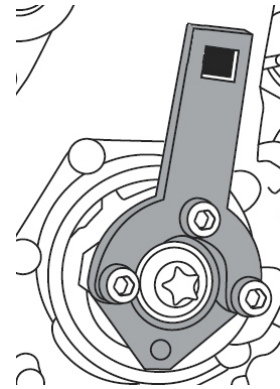

D

Ketten-Spannhebel wird zum Arretieren der Steuerkette verwendet, wenn die Dichtung ausgetauscht wird. Das Werkzeug wird so befestigt, dass es mit der Serviceöffnung in der Motorabdeckung fluchtet, damit der Stift auf die Rippen des Kettengleitstücks wirkt. Den Kolben vom Kettenspanner mit dem Hebel zurückziehen, bis dieser sich in die Verriegelungsposition bewegt.

Sicherstellen, dass der Spanner vollständig ausgefahren ist, bevor er zurückgezogen wird.

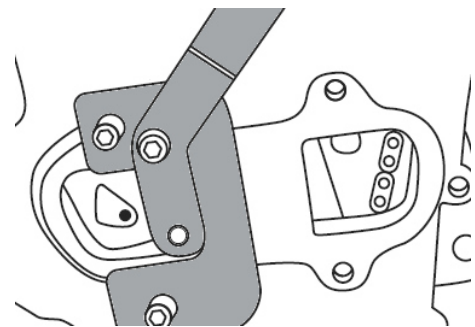

C

Die Nockenwellen-Einstellwerkzeuge (2 Stück) wird zur Einstellung der Nockenwellen verwendet, die Nockenwellen bleiben nach Einsetzen in der Einstellposition arretiert. Zur Montage der Werkzeuge müssen zuerst die Verschlussstopfen entfernt werden. Ein Stopfen befindet sich an der Vorderseite des Ventildeckels und der andere an der Rückseite. Zum Erreichen der Stopfen muss die Kraftstoffleitung und der Kabelbaum angehoben werden.

Die Werkzeuge so montieren, dass die inneren Schlüsselflächen der Werkzeuge horizontal stehen.

Die Werkzeuge sind korrekt montiert, wenn sie sich leicht nach innen drücken lassen.

Hinweis: die Einstellwerkzeuge dienen zum Ausrichten der Nockenwellen, nicht zum Arretieren der Nockenwellen beim z.B. Lösen der Nockenwellenräder.

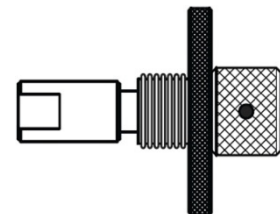
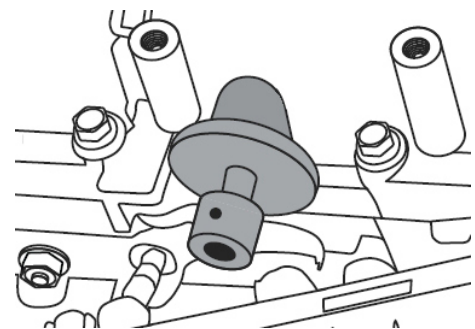

B / F Kurbelwellen- Einstellwerkzeug**F** 8 mm Stift für Fiat – **B** für Opel bzw. Suzuki

Diese Werkzeuge dienen dem Einstellen der Kurbelwelle. Die Kurbelwelle wird nach Montage der Werkzeuge in Einstellposition gehalten und gewährleisten so eine korrekte Ausrichtung der Kurbelwelle bei Montage der Kette.

Achtung: Verwenden Sie das Werkzeug niemals als Gegenhalter.

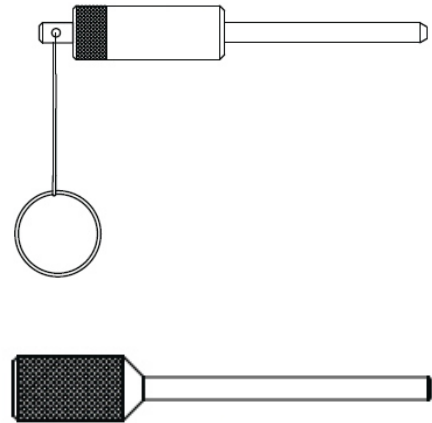
**E**

Das Kurbelwellen-Arretierwerkzeug wird dazu verwendet die Kurbelwelle (Schwungradseitig) in Einstellposition zu halten. Findet Anwendung bei kompletter Motorüberholung und bei demontiertem Motor. Das Werkzeug wird an den Befestigungsschrauben vom Schwungrad montiert (Schwungrad muss dafür demontiert sein).

Achtung. Beachten Sie die Hinweise des Fahrzeugherstellers.

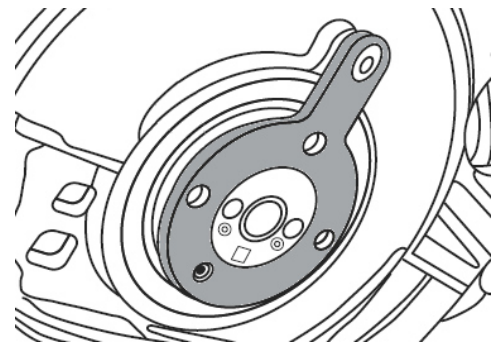

Engine Timing Tool Set

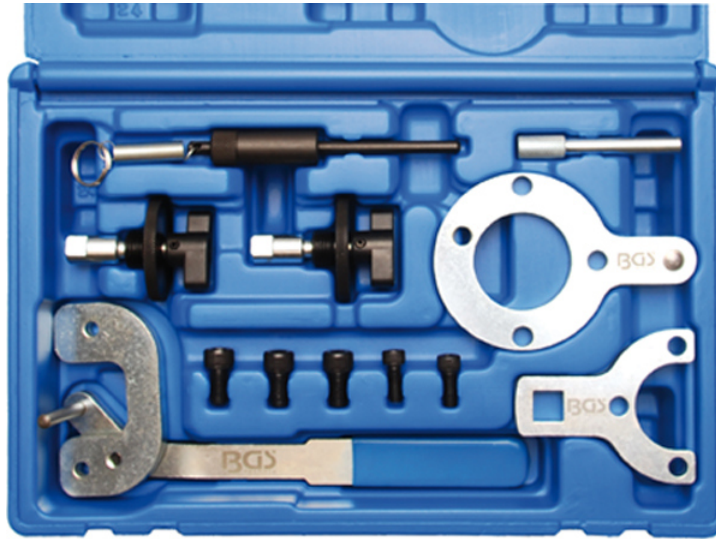

GENERAL

This timing tool set enables checking and adjusting of the engine timing and is suitable for following models:

Fiat:

Punto 1.3 JTD Multi-Jet 188A9.000 2003 - 2007
Panda 1.3 JTD Multi-Jet 169A1.000 & 188A8.000 2003 - 2009
Idea 1.3 JTD Multi-Jet 199A3.000 & 188A9.000 2004 - 2006
Doblo 1.3 JTD Multi-Jet 188A9.000 2004 - 2006
Doblo Cargo 1.3 JTD 188A9.000 2004 - 2006

Opel (Vauxhall):

Agila 1.3 CDTi Z13DT 2003 - 2008
Corsa-C 1.3 CDTi Z13DT 2003 - 2007
Combo-C 1.3 CDTi Z13DT 2003 - 2009
Corsa-D 1.3 CDTi Z13DTH & Z13DTJ 2006 - 2009
Astra-H 1.3 CDTi Z13DTH 2004 - 2009
Tigre-B 1.3 CDTi Z13DT 2004 - 2009
Meriva 1.3 CDTi Z13DT & Z13DTJ 2004 - 2009

Suzuki:

Ingis 1.3 CDTi Z13DT 2003 - 2009
Wagon 1.3 CDTi Z13DT 2003 - 2009
Swift 1.3 CDTi Z13DT 2003 - 2010

Ford:

KA 1.3 TDCi

SAFETY ADVICE

- DO NOT use the set if any parts are missing or damaged.
- Never lay tools on the vehicle's battery. This may short the terminals together.
- Be careful when working on running engines. Loose clothes, tools and other things can be caught up in revolving parts which may lead to serious injuries.
- Keep children and other unauthorised persons away from the working area.
- Be careful when working on hot engines – risk of burn!
- Remove the ignition key before repair so that the engine will not start unintentionally.
- This manual is just brief information and will not replace a garage handbook.
- Always consult specific service literature for information about torques, assemblies and disassemblies etc.
- After any successful maintenance and before starting the engine, you should rotate the engine for two turns manually to check the new control time.
- Do not use cleaning fluids on belts, sprockets or rollers
- Turn the engine in the normal direction (clockwise unless stated otherwise)

TOOLS

A
Counterholder wrench for
crankshaft sprocket

to be used as OEM
Fiat OEM 1 871 000 200
Ford OEM 303-1469

Opel
Vauxhall OEM KM-662-C

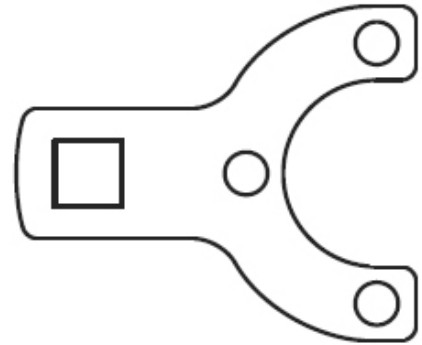

B
Crankshaft timing tool

to be used as OEM
Opel (Vauxhall) EN 46785
Opel (Vauxhall) KM 955
Suzuki 09912-38300

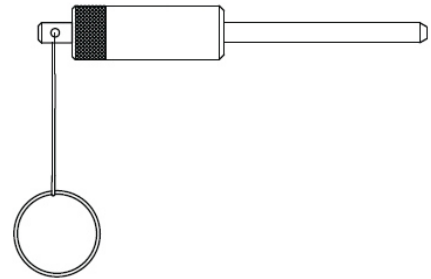

C
Camshaft timing tool

to be used as OEM
Fiat 1 871 000 900
Fiat 1 860 985 000
Ford 303-1472
Opel (Vauxhall) EN 46781
Suzuki 09917-68610

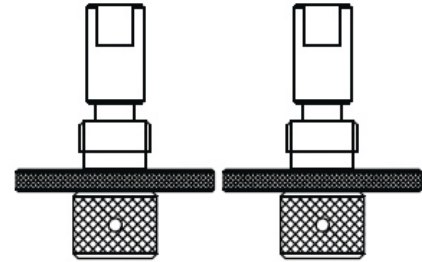

D
Chain tensioner lever

to be used as OEM
Fiat 1 870 900 400

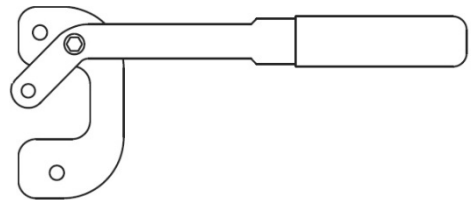

E
Crankshaft locking tool

to be used as OEM
Fiat 1 870 900 300
Ford 303-1468

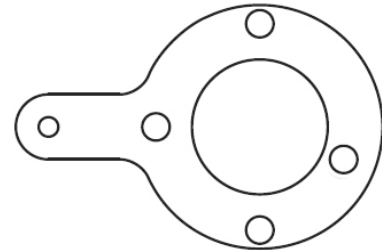

F
Crankshaft timing tool

Fiat 8 mm

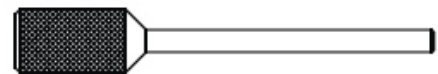

INSTRUCTIONS

A

Use this tool to hold the Crankshaft Pulley Flange still whilst releasing the pulley flange centre bolt (left hand thread). In order to gain access to the pulley flange the pulley must first be removed by removing the 4 outer fixings pulley fixings.

Note: Do not release the pulley flange centre bolt until the cam and crank timing pins are in place.

Do not attempt to loosen or tighten the pulley centre bolt with out holding the flange with the flange tool or the crankshaft and camshaft tools will be damaged.

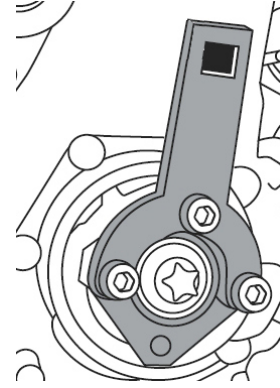

D

The Timing Chain tensioning tool is used to clamp the timing chain when replacing the gasket on the one-piece cylinder head. The tool is attached in alignment with the inspection opening on the engine control cover so that the pin acts upon the ribs of the chain slider. Retract the chain tensioner piston so that it moves back to its locked position using the lever. Ensure the tensioner has fully extended before attempting to retract it.

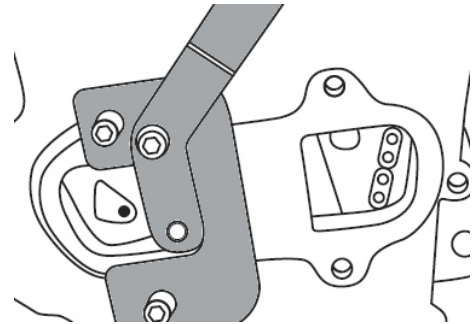

C

These camshaft locking tools are used to lock the camshafts in position.

Access must first be gained to the blanking plugs that are positioned one on the front of the cam cover and one on the rear of the cam cover. Lift the high pressure fuel rail and engine wiring harness to gain access.

Remove the blanking plugs and screw the locking tools into place with the flats on the inner section of the tools horizontal. The tools are correctly fitted when the inner section of the tools can be easily pushed in with finger pressure.

Note: These tools are for setting the position of the camshafts.

Do not attempt to loosen or tighten any fixings on the camshaft using these tools to lock the camshaft as damage will result.

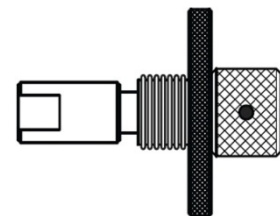
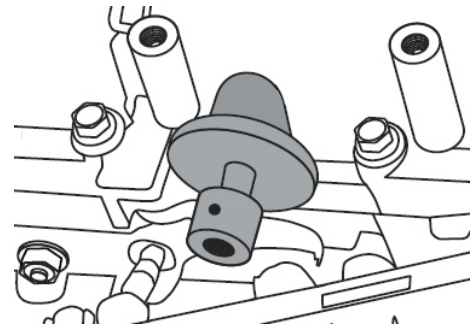

B / F Crankshaft timing tool**F** 8 mm Pin for Fiat – **B** für Opel or Suzuki

The flywheel alignment pins are used to lock the position of the flywheel to ensure the crankshaft is in the correct timed position to match the camshafts.

Note: These tools are for setting the position of the crankshaft, do not attempt to loosen or tighten any fixings on the crankshaft using these tools to lock the crank as damage will result.

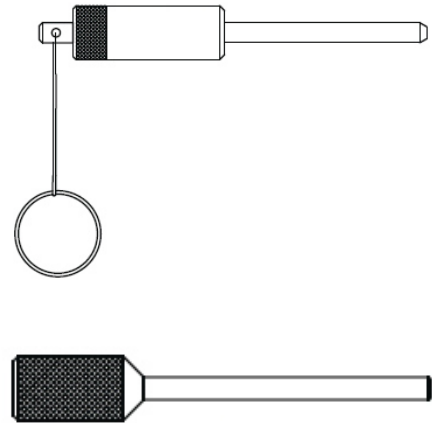
**E**

This tool is used to set the control position of the crankshaft (flywheel end) with engine removed when a complete engine rebuild is required. The tool is attached to the crankshaft using the three fasteners (From Item A) in place of the flywheel. Always follow the vehicle manufacturers' instructions.

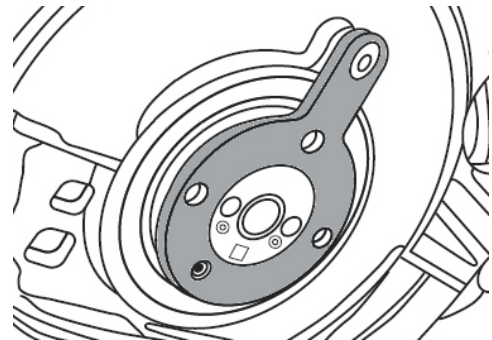

Engine Timing Tool Set

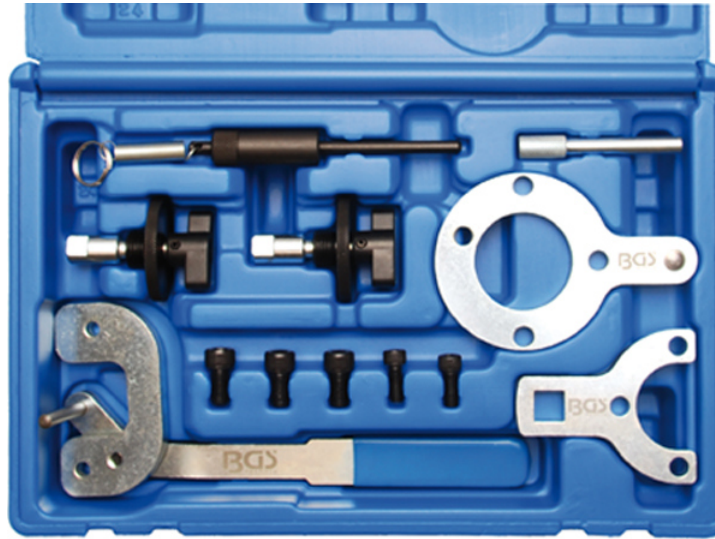

GENERAL

This timing tool set enables checking and adjusting of the engine timing and is suitable for following models:

Fiat:

Punto 1.3 JTD Multi-Jet 188A9.000 2003 - 2007
Panda 1.3 JTD Multi-Jet 169A1.000 & 188A8.000 2003 - 2009
Idea 1.3 JTD Multi-Jet 199A3.000 & 188A9.000 2004 - 2006
Doblo 1.3 JTD Multi-Jet 188A9.000 2004 - 2006
Doblo Cargo 1.3 JTD 188A9.000 2004 - 2006

Opel (Vauxhall):

Agila 1.3 CDTi Z13DT 2003 - 2008
Corsa-C 1.3 CDTi Z13DT 2003 - 2007
Combo-C 1.3 CDTi Z13DT 2003 - 2009
Corsa-D 1.3 CDTi Z13DTH & Z13DTJ 2006 - 2009
Astra-H 1.3 CDTi Z13DTH 2004 - 2009
Tigre-B 1.3 CDTi Z13DT 2004 - 2009
Meriva 1.3 CDTi Z13DT & Z13DTJ 2004 - 2009

Suzuki:

Ingis 1.3 CDTi Z13DT 2003 - 2009
Wagon 1.3 CDTi Z13DT 2003 - 2009
Swift 1.3 CDTi Z13DT 2003 - 2010

Ford:

KA 1.3 TDCi

SAFETY ADVICE

- DO NOT use the set if any parts are missing or damaged.
- Never lay tools on the vehicle's battery. This may short the terminals together.
- Be careful when working on running engines. Loose clothes, tools and other things can be caught up in revolving parts which may lead to serious injuries.
- Keep children and other unauthorised persons away from the working area.
- Be careful when working on hot engines – risk of burn!
- Remove the ignition key before repair so that the engine will not start unintentionally.
- This manual is just brief information and will not replace a garage handbook.
- Always consult specific service literature for information about torques, assemblies and disassemblies etc.
- After any successful maintenance and before starting the engine, you should rotate the engine for two turns manually to check the new control time.
- Do not use cleaning fluids on belts, sprockets or rollers
- Turn the engine in the normal direction (clockwise unless stated otherwise)

TOOLS

A
Counterholder wrench for
crankshaft sprocket

to be used as OEM
Fiat OEM 1 871 000 200
Ford OEM 303-1469

Opel
Vauxhall OEM KM-662-C

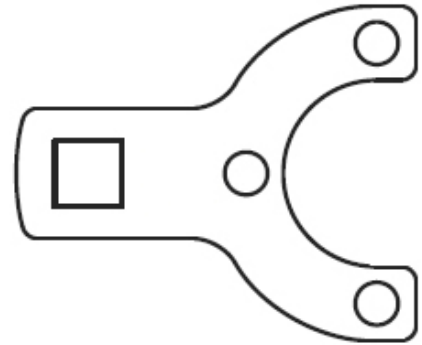

B
Crankshaft timing tool

to be used as OEM
Opel (Vauxhall) EN 46785
Opel (Vauxhall) KM 955
Suzuki 09912-38300

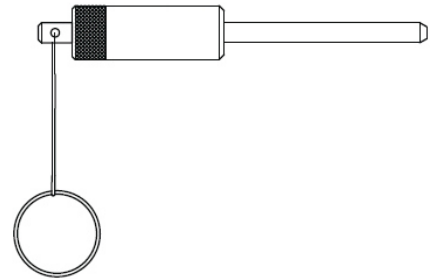

C
Camshaft timing tool

to be used as OEM
Fiat 1 871 000 900
Fiat 1 860 985 000
Ford 303-1472
Opel (Vauxhall) EN 46781
Suzuki 09917-68610

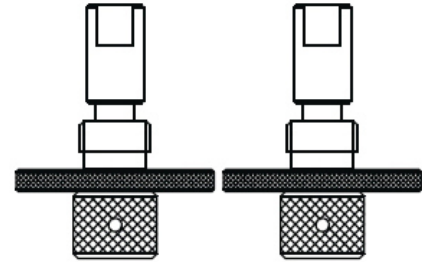

D
Chain tensioner lever

to be used as OEM
Fiat 1 870 900 400

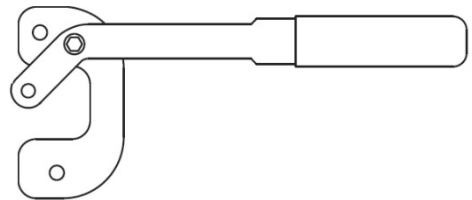

E
Crankshaft locking tool

to be used as OEM
Fiat 1 870 900 300
Ford 303-1468

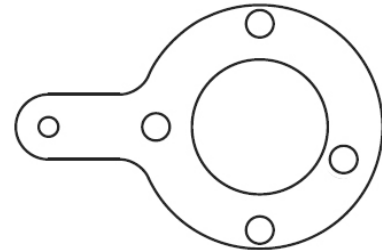

F
Crankshaft timing tool

Fiat 8 mm

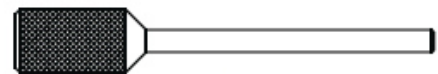

INSTRUCTIONS

A

Use this tool to hold the Crankshaft Pulley Flange still whilst releasing the pulley flange centre bolt (left hand thread). In order to gain access to the pulley flange the pulley must first be removed by removing the 4 outer fixings pulley fixings.

Note: Do not release the pulley flange centre bolt until the cam and crank timing pins are in place.

Do not attempt to loosen or tighten the pulley centre bolt with out holding the flange with the flange tool or the crankshaft and camshaft tools will be damaged.

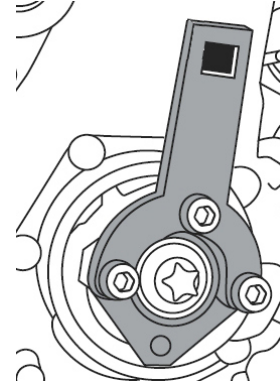

D

The Timing Chain tensioning tool is used to clamp the timing chain when replacing the gasket on the one-piece cylinder head. The tool is attached in alignment with the inspection opening on the engine control cover so that the pin acts upon the ribs of the chain slider. Retract the chain tensioner piston so that it moves back to its locked position using the lever. Ensure the tensioner has fully extended before attempting to retract it.

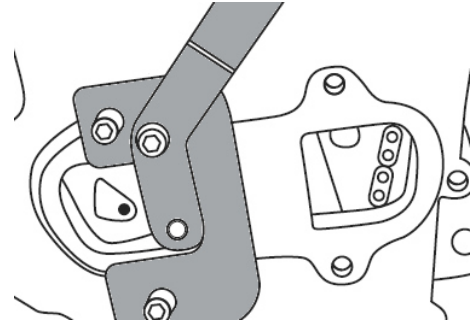

C

These camshaft locking tools are used to lock the camshafts in position.

Access must first be gained to the blanking plugs that are positioned one on the front of the cam cover and one on the rear of the cam cover. Lift the high pressure fuel rail and engine wiring harness to gain access.

Remove the blanking plugs and screw the locking tools into place with the flats on the inner section of the tools horizontal. The tools are correctly fitted when the inner section of the tools can be easily pushed in with finger pressure.

Note: These tools are for setting the position of the camshafts.

Do not attempt to loosen or tighten any fixings on the camshaft using these tools to lock the camshaft as damage will result.

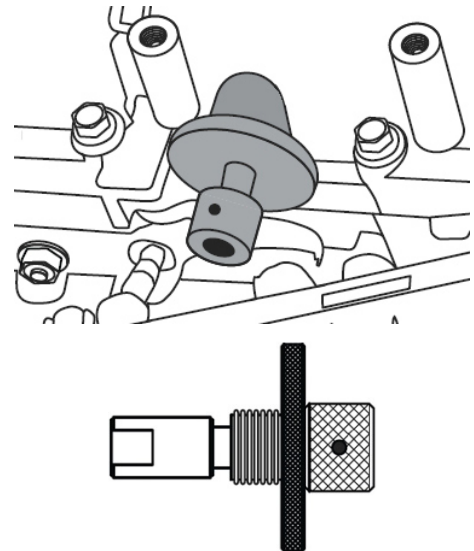

B / F Crankshaft timing tool**F** 8 mm Pin for Fiat – **B** für Opel or Suzuki

The flywheel alignment pins are used to lock the position of the flywheel to ensure the crankshaft is in the correct timed position to match the camshafts.

Note: These tools are for setting the position of the crankshaft, do not attempt to loosen or tighten any fixings on the crankshaft using these tools to lock the crank as damage will result.

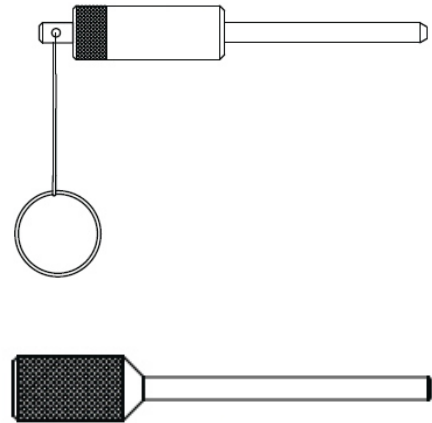
**E**

This tool is used to set the control position of the crankshaft (flywheel end) with engine removed when a complete engine rebuild is required. The tool is attached to the crankshaft using the three fasteners (From Item A) in place of the flywheel. Always follow the vehicle manufacturers' instructions.

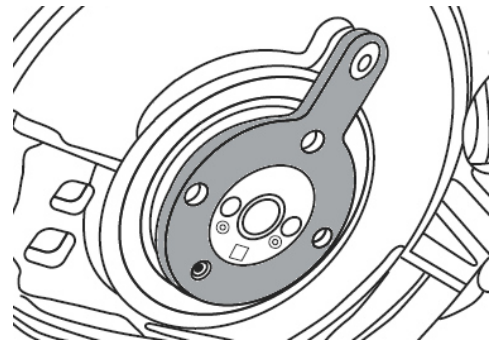

Set di attrezzi per il tempismo del motore

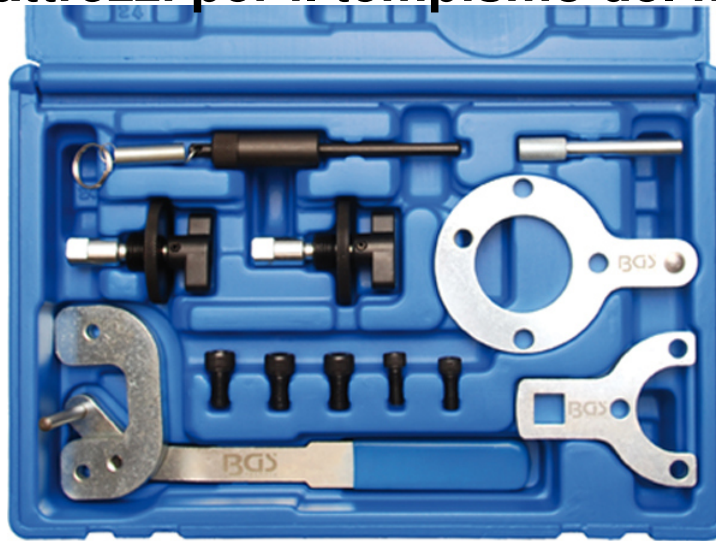

GENERALE

Questo set di attrezzi per il tempismo è capace di controllare e regolare il tempismo del motore e è adatto per i seguenti modelli:

Fiat:	Punto 1.3 JTD Multi-Jet 188A9.000 2003 - 2007 Panda 1.3 JTD Multi-Jet 169A1.000 & 188A8.000 2003 - 2009 Idea 1.3 JTD Multi-Jet 199A3.000 & 188A9.000 2004 - 2006 Doblo 1.3 JTD Multi-Jet 188A9.000 2004 - 2006 Doblo Cargo 1.3 JTD 188A9.000 2004 - 2006
Opel (Vauxhall):	Agila 1.3 CDTi Z13DT 2003 - 2008 Corsa-C 1.3 CDTi Z13DT 2003 - 2007 Combo-C 1.3 CDTi Z13DT 2003 - 2009 Corsa-D 1.3 CDTi Z13DTH & Z13DTJ 2006 - 2009 Astra-H 1.3 CDTi Z13DTH 2004 - 2009 Tigre-B 1.3 CDTi Z13DT 2004 - 2009 Meriva 1.3 CDTi Z13DT & Z13DTJ 2004 - 2009
Suzuki:	Ingis 1.3 CDTi Z13DT 2003 - 2009 Wagon 1.3 CDTi Z13DT 2003 - 2009 Swift 1.3 CDTi Z13DT 2003 - 2010
Ford:	KA 1.3 TDCi

AVVISO DI SICUREZZA

- NON usare il set se dei pezzi sono stati persi o danneggiati.
- Non applicare mai gli attrezzi sulla batteria del veicolo. Questi terminali possono provocare un corto circuito.
- Fare attenzione quando si lavora su motori accesi. Vestiti, attrezzi o alter cose sciolte possono essere prese in parti girevoli che possono causare gravi danni.
- Tenere i bambini e alter persone non autorizzate lontano dall'area di lavoro.
- Fare attenzione quando si lavora su motori caldi – rischio di bruciatura!
- Rimuovere la chiave di accensione prima di riparare così che il motore non partirà intenzionalmente
- Questo manuale dà solo brevi informazioni e non sostituirà il manuale da officina.
- Consultare sempre il libretto di servizio specifico per informazioni su torsioni, assemblaggio e disassemblaggio ecc.
- Dopo qualsiasi manutenzione di successo e prima di accendere il motore, si dovrebbe ruotare il motore per due giri manualmente per controllare il nuovo tempismo.
- Non usare liquidi per la pulizia su cinghie, ruote dentate o ruote.
- Ruotare il motore nella direzione normale (in senso orario sen non diversamente specificato).

ATTREZZI

A
Chiave di contro supporto per la ruota dentate dell'albero a motore

è usato come OEM
Fiat OEM 1 871 000 200
Ford OEM 303-1469

Opel
Vauxhall OEM KM-662-C

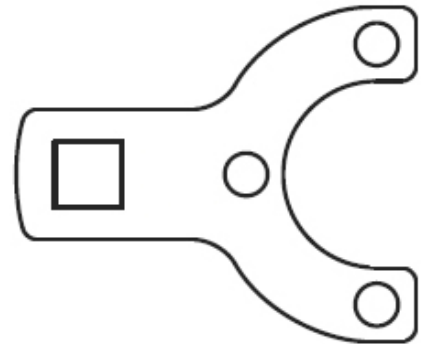

B
Attrezzo per il tempismo dell'albero a motore

è usato come OEM
Opel (Vauxhall) EN 46785
Opel (Vauxhall) KM 955
Suzuki 09912-38300

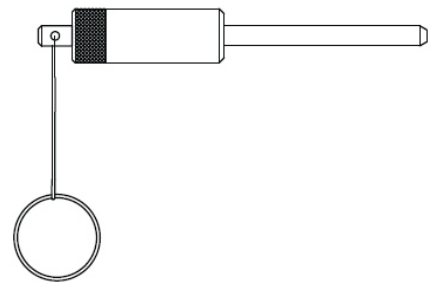

C
Attrezzo per il tempismo per l'albero a camme

è usato come OEM
Fiat 1 871 000 900
Fiat 1 860 985 000
Ford 303-1472
Opel (Vauxhall) EN 46781
Suzuki 09917-68610

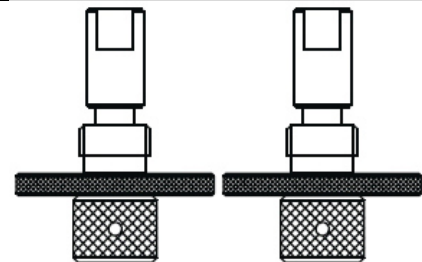

D
Leva per il tenditore della catena

è usato come OEM
Fiat 1 870 900 400

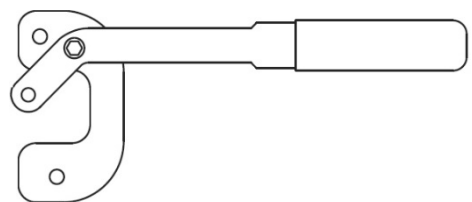

E
Attrezzo di chiusura dell'albero a motore

è usato come OEM
Fiat 1 870 900 300
Ford 303-1468

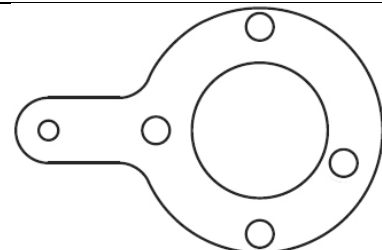

F
Attrezzo per il tempismo dell'albero a motore

Fiat 8 mm



ISTRUZIONI

A

Usare questo attrezzo per tenere la flangia della puleggia dell'albero a camme mentre si sta ancora rilasciando il bullone al centro della flangia della puleggia (filettatura sinistra). Al fine di ottenere accesso alla flangia della puleggia la puleggia deve essere prima rimossa rimuovendo i 4 fissaggi esterni della puleggia.

Nota: Non rilasciare il bullone al centro della flangia della puleggia fino a quando i perni del tempismo della camma e dell'albero sono in posizione.

Non tentare di allentare o stringere il bullone al centro della puleggia senza tenere la flangia con l'attrezzo della flangia o gli attrezzi dell'albero a motore e dell'albero a camme si danneggeranno.

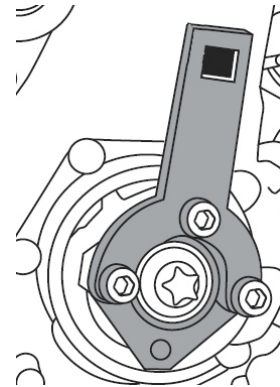

D

L'attrezzo per il tempismo del tensionamento della catena è usato per serrare la catena per il tempismo quando si sostituisce la guarnizione su un pezzo della testa del cilindro. L'attrezzo è attaccato in allineamento con un'apertura di ispezione sulla cover di controllo del motore così che il perno agisca sulle nervature dello scorcio catena. Ritrarre il pistone del tenditore a catena così che torni indietro alla sua posizione di chiusura usando la leva.

Assicurarsi che il tenditore abbia una piena estensione prima di tentare di ritrarlo.

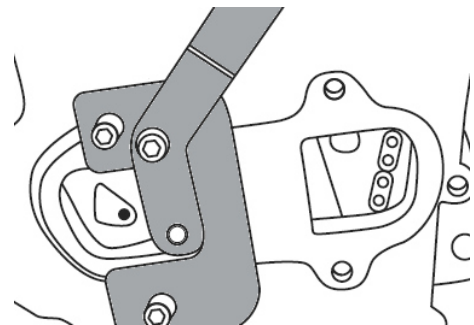

C

Questi attrezzi di chiusura dell'albero a camme sono usati per chiudere gli alberi a camme in posizione.

L'accesso deve essere ottenuto alla chiusura dei tappi che sono posizionati uno di fronte alla cover della camma e uno nella parte posteriore della cover della camma. Alzare la barra dell'alta pressione del carburante e attaccare il circuito al motore per ottenere l'accesso.

Rimuovere i tappi di chiusura e avvitare gli attrezzi di chiusura nel posto con i piatti sulla sezione interna degli attrezzi orizzontali.

Gli attrezzi sono inseriti correttamente quando la sezione interna degli attrezzi può essere facilmente spinta con la pressione di un dito.

Nota: Questi attrezzi sono per regolare la posizione dell'albero a camme.

Non tentare di allentare o stringere qualsiasi fissaggio sull'albero a camme usando questi attrezzi per chiudere l'albero a camme perché si danneggerebbe il risultato.

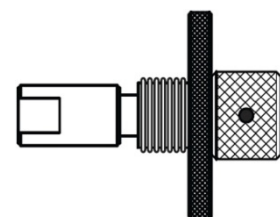
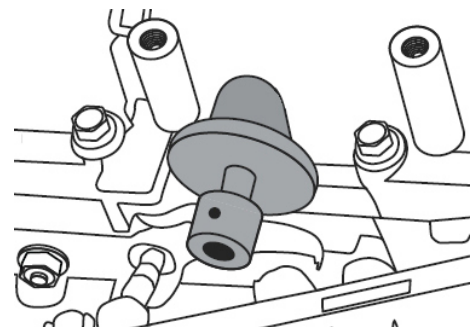

B / F Attrezzo per il tempismo dell'albero a motore

F 8 mm perno per Fiat – **B** per Opel o Suzuki

I perni per l'allineamento del volano sono usati per chiudere la posizione del volano per assicurare che l'albero motore sia nella posizione di tempismo corretta per combinarsi con l'albero a camme.

Nota: Questi attrezzi sono per regolare la posizione dell'albero a motore, non tentare di allentare o stringere qualsiasi fissaggio sull'albero a motore usando questi attrezzi per chiudere il motore si danneggia il risultato.

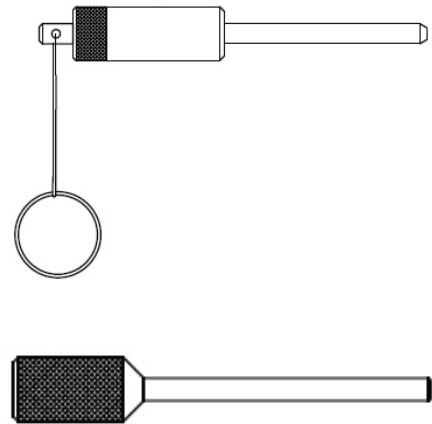

E

Questo attrezzo è usato per impostare il controllo dell'albero a motore

(estremità del volano) con motore rimosso quando sia stato richiesto di essere ricostruito un motore completo.

L'attrezzo è attaccato all'albero a motore usando le tre viti (dall'articolo A) nel posto del volano.

Seguire sempre le istruzioni del costruttore del veicolo.

